

HS-150T Premium Accelerometer

AC acceleration and temperature output via Braided Cable

Key Features

- Temperature output
- Customisable features
- Premium design

Industries

Building services, Pulp and Paper, Mining, Metals, Utilities, Automotive, Water, Pharmaceutical

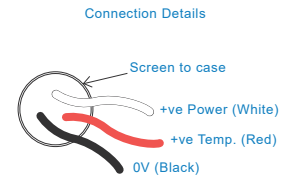
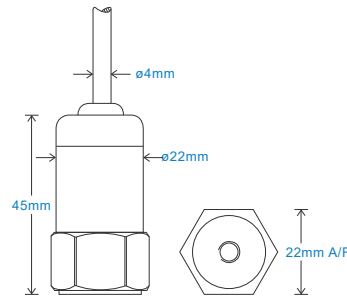

Technical Performance

Mounted Base Resonance	see 'How To Order' table (nominal)
Sensitivity	see: 'How To Order' table $\pm 10\%$ Nominal 80Hz at 22°C
Frequency Response	1.5Hz (90cpm) to 10kHz (600kcpm) $\pm 5\%$ 0.5Hz (30cpm) to 12kHz (720kcpm) $\pm 10\%$ 0.2Hz (12cpm) to 15kHz (900kcpm) $\pm 3dB$
Isolation	Base isolated
Range	see: 'How To Order' table
Temperature	10 mV/°C standard 100°C - Option 150°C
Transverse Sensitivity	Less than 5%

Mechanical

Case Material	Stainless Steel
Sensing Element/Construction	PZT/Shear
Mounting Torque	8Nm
Weight	106gms (nominal) body only
Maximum Cable Length	1000 metres
Standard Cable Length	5 metres
Screened Cable	Braided - length to be specified with order
Mounting Threads	see: 'How To Order' table

Electrical

Excitation Voltage:	18-30Volts DC
Electrical Noise	0.1mg max
Current Range	0.5mA to 8mA
Bias Voltage	10 - 12 Volts DC
Settling Time	1 second
Output Impedance	200 Ohms max.
Case Isolation	$>10^8$ Ohms at 500 Volts

Environmental

Operating Temperature Range	-55 to 150°C
Sealing	IP65
Maximum Shock	5000g
EMC	EN61326-1:2013

Typical Frequency Response (at 100mV/g)

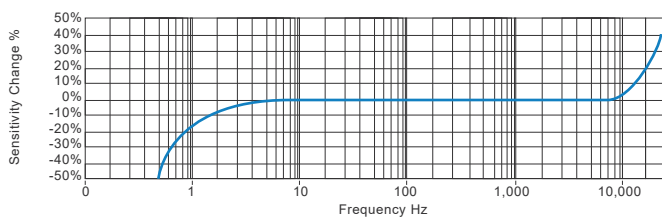

Applications

Fans, Motors, Pumps, Compressors, Centrifuges, Conveyors, Air Handlers, Gearboxes, Rolls, Dryers, Presses, Cooling, VAC, Spindles, Machine Tooling, Process Equipment

Vibration sensor should be firmly fixed to a flat surface (spot face surface may be needed to be produced and cable anchored to sensor body.)

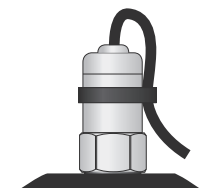

How To Order

Product Prefix HS - Hansford Sensors	Product Series 150 - Premium Industrial Vibration Sensor	Cable Length (if integral cable) QXX - length specified in metres												
H	S	1	5	0	T	X	X	X	X	X	X	X	X	X
Extra Options (if required) F - Filtered HT - High Temperature maximum 150°C L - 316L Stainless Steel S - 90° Side Exit T - Temperature Output Y - 5% tolerance on sensitivity	Sensitivity 010 - 10mV/g 030 - 30mV/g 050 - 50mV/g 100 - 100mV/g 250 - 250mV/g 500 - 500mV/g	Range $\pm 800g$ $\pm 250g$ $\pm 160g$ $\pm 80g$ $\pm 32g$ $\pm 16g$	Resonant Frequency 34kHz (2,040kcpm) 33kHz (1,980kcpm) 32kHz (1,920kcpm) 30kHz (1,800kcpm) 28kHz (1,680kcpm) 26kHz (1,560kcpm)	Cable/Connector 01 - PUR 03 - Braided 07 - Silicon 15 - Flame Retardant 52 - 3 Pin MS 54 - M12	Mounting Threads 01 - 1/4-28" UNF Female 02 - 1/4-28" UNF Male 05 - Quick Fit Female 06 - M6 x 1mm Male 08 - M8 x 1.25mm Male 10 - M10 x 1.5mm Male									



www.hansfordsensors.com
sales@hansfordsensors.com

We reserve the right to alter the specification of this product without prior notice

TS272.7

